



GANTRY CRANE

Carney Fabricating gantry cranes are available in both fixed or stationary and mobile configurations available with either manual or powered wheels. Our unique hydraulic drive system uses positive traction on both sides to reduce twist of the structure so that the crane operates smoothly with or without the load.

For added reassurance our gantry cranes are equipped with a floor guide rail on one side which allows for workspace utilization. We also offer solutions for permanent floor mounting, reversed braces, cantilevered design or solutions to have legs operator at different floor levels.

GET IN TOUCH

info@carneyfabricating.com
www.carneyfabricating.com

Tel: 1.905.564.0303
Toll free: 1.866.THE.BULL

2A - 14 Reagan Road
Brampton Ontario L7A 1B9

Gantry Crane

Designed & engineered to allow for slight modifications to standard designs to meet your operating applications.

What is a Gantry Crane?

A gantry crane is simply a free-standing crane structure with a single or double fixed beams supported with legs that may or may not contain wheels at a four-corner base. Gantry cranes are used to straddle an object, workspace or area of travel. They are also referred to as portal cranes in the sense the crane straddles the empty space under the crane structure. Gantry cranes are the alternative to bridge cranes and do not require a runway since the crane structure is supported by the floor surface.

Product Options

- Radio remote controls
- Available in permanent floor-mounting or on-rail models
- Adjustable height, span, and tread (T-series)
- Customization of heights and weight capacity available

Product Applications

- Manufacturing work station areas
- Water treatment plants
- Maintenance shops
- Auto repair
- Construction
- Elevator service and construction

Gantry Crane

Features and Benefits

- Lifting capacities up to 3 tons (6000 lbs)

Our gantry cranes can accommodate a variety of lifting capacities dependant on operational needs

- Standard spans up to 30 feet

A variety of lengths are available up to a maximum of 30 feet

- Exterior coating and stainless steel motors

Built for indoor or outdoor applications

- Portable Gantries

Quickly dissassembled for transport by a service truck with a portable gantry crane

- A tagline or festoon system

Outfit your crane with a festoon or tagline system to deliver electrical power to your hoist or trolley

- Simple height and span adjustments

Safely adjust height and span of the crane

- Powered travel / CE approved

CE approved and electrically powered floor travel available with any system.

- Ideal for warehouses and welding shops

Perfect for small spaces and warehousing applications

- In accordance with current safety standards

Designed to meet current North American Standards

- Ergonomic dash panel and control station

Dashboard and control station designed for operator comfort

Types of Gantry Cranes

- Full gantry crane is when the load being held by the structure is always re
- Stationary A-frame style gantry cranes are engineered without wheels and is placed in a specific work station area. Carney Fabricating SGC model.
- Hydraulic A-frame style gantry cranes are equipped with wheels and hydraulic power pack for floor travel. Carney Fabricating HGC model.
- Manual gantry crane considered one of the most popular types of gantry cranes is similar to SGC model but will contain castors to maneuver the crane from one location to another manually.
- Cantilevered gantry cranes
- Semi-gantry cranes or single leg gantries is simply a hybrid between a bridge crane and a gantry crane. One side of the crane moves on a partial runway supported by building columns and one leg free standing on the floor surface.
- Wall gantry or “wall crawler cranes” are cranes that are supported by wall tracks and traverse along the length of a building.

Product Specs

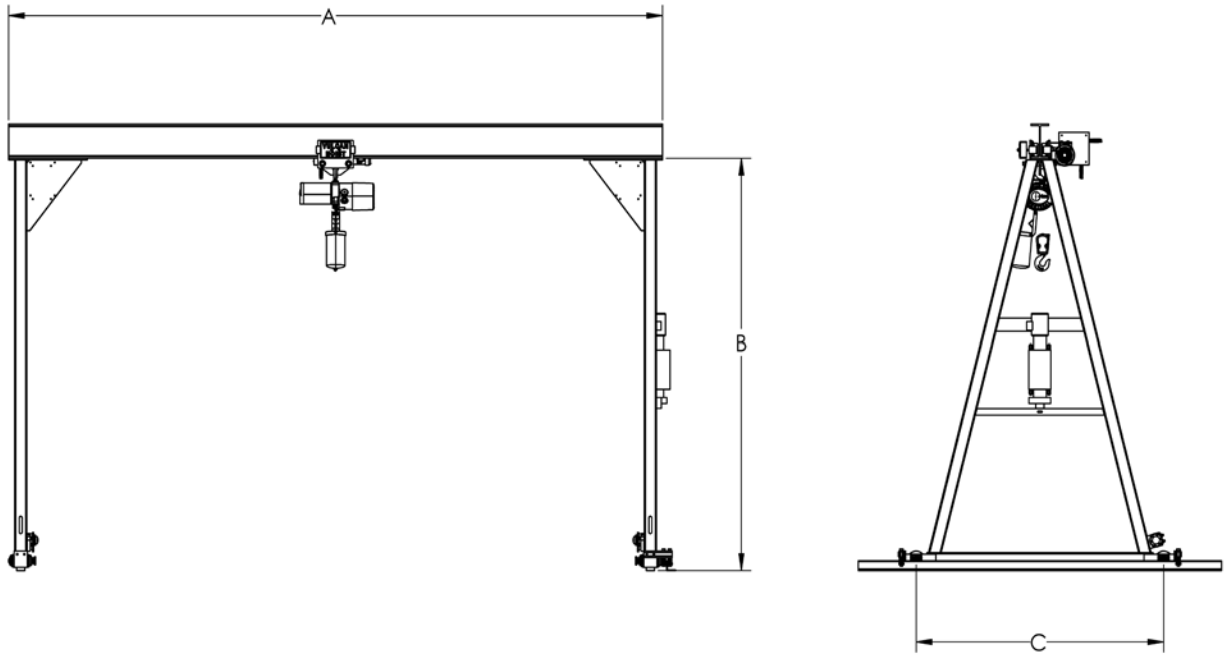

GENERAL SPECIFICATIONS	
Maximum Lift Capacity	3 Tons
Custom Units Available	

Gantry Crane

SPECIFICATIONS

CAPACITY (Tons)	MODEL	TYPE	CLEARANCE (Beam)	LENGTH (FT)
2	SGC-10-10-2	Stationary	10' - 6"	10'
	SGC-10-12-2	Stationary	10' - 6"	12'
	SGC-10-14-2	Stationary	10' - 6"	14'
	SGC-10-16-2	Stationary	10' - 6"	16'
	SGC-10-18-2	Stationary	10' - 6"	18'
	SGC-10-22-2	Stationary	10' - 6"	22'
	SGC-10-24-2	Stationary	10' - 6"	24'
	SGC-10-26-2	Stationary	10' - 6"	26'
	SGC-10-28-2	Stationary	10' - 6"	28'
	SGC-10-30-2	Stationary	10' - 6"	30'
SGC-10-32-2	Stationary	10' - 6"	32'	
2	MGC-10-10-2	Manual	10' - 6"	10'
	MGC-10-12-2	Manual	10' - 6"	12'
	MGC-10-14-2	Manual	10' - 6"	14'
	MGC-10-16-2	Manual	10' - 6"	16'
	MGC-10-18-2	Manual	10' - 6"	18'
	MGC-10-20-2	Manual	10' - 6"	20'
2	HGC-10-10-2	Hydraulic	10' - 6"	10'
	HGC-10-12-2	Hydraulic	10' - 6"	12'
	HGC-10-14-2	Hydraulic	10' - 6"	14'
	HGC-10-16-2	Hydraulic	10' - 6"	16'
	HGC-10-18-2	Hydraulic	10' - 6"	18'
	HGC-10-20-2	Hydraulic	10' - 6"	20'
	HGC-10-22-2	Hydraulic	10' - 6"	22'
	HGC-10-28-2	Hydraulic	10' - 6"	28'
3	SGC-10-10-3	Stationary	10' - 6"	10'
	SGC-10-12-3	Stationary	10' - 6"	12'
	SGC-10-14-3	Stationary	10' - 6"	14'
	SGC-10-16-3	Stationary	10' - 6"	16'
	SGC-10-18-3	Stationary	10' - 6"	18'
	SGC-10-23-3	Stationary	10' - 6"	23'
3	MGC-10-10-3	Manual	10' - 6"	10'
	MGC-10-12-3	Manual	10' - 6"	12'
	MGC-10-14-3	Manual	10' - 6"	14'
	MGC-10-16-3	Manual	10' - 6"	16'
	MGC-10-18-3	Manual	10' - 6"	18'

Gantry Crane

SPECIFICATIONS

CAPACITY (Tons)	MODEL	TYPE	CLEARANCE (Beam)	LENGTH (FT)	VOLTAGE
3	HGC-10-10-3-xxx	Hydraulic	10'- 6"	10'	415/480/575
	HGC-10-12-3-xxx	Hydraulic	10'- 6"	12'	415/480/575
	HGC-10-14-3-xxx	Hydraulic	10'- 6"	14'	415/480/575
	HGC-10-16-3-xxx	Hydraulic	10'- 6"	16'	415/480/575
	HGC-10-18-3-xxx	Hydraulic	10'- 6"	18'	415/480/575
	HGC-10-20-3-xxx	Hydraulic	10'- 6"	20'	415/480/575
	HGC-10-22-3-xxx	Hydraulic	10'- 6"	22'	415/480/575
	HGC-10-24-3-xxx	Hydraulic	10'- 6"	24'	415/480/575

HOISTS & TROLLEYS

CAPACITY (Tons)	TYPE	SPEED	VOLTAGE
2	Manual hoist / trolley	Single	-
	Electric hoist / push trolley	Single	415/480/575
	Electric hoist / electric trolley	Single	415/480/575
	Electric hoist / push trolley	Double	415/480/575
	Electric hoist / electric trolley	Double	415/480/575

CAPACITY (Tons)	TYPE	SPEED	VOLTAGE
3	Manual hoist / trolley	Single	-
	Electric hoist / push trolley	Single	415/480/575
	Electric hoist / electric trolley	Single	415/480/575
	Electric hoist / push trolley	Double	415/480/575
	Electric hoist / electric trolley	Double	415/480/575

Model/Part Number Breakdown

Example: HGC-10-18-2-480

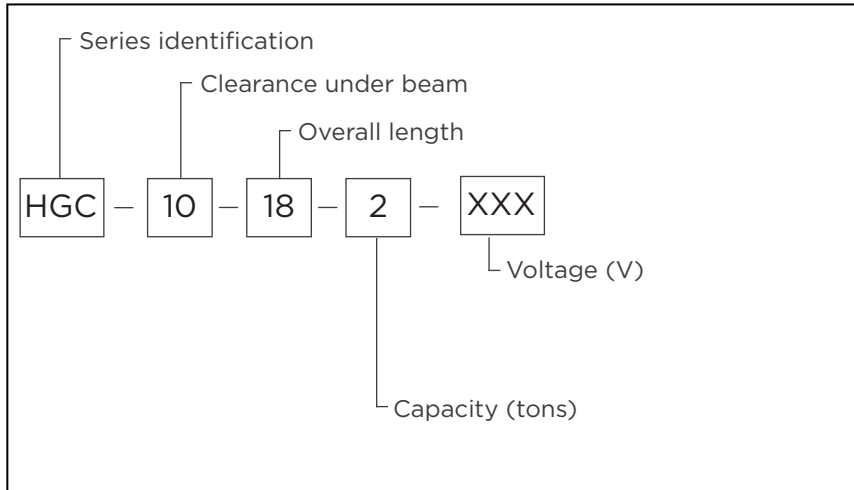

Gantry crane full front view with hoist



Gantry crane hoist controller

GET IN TOUCH

info@carneyfabricating.com
www.carneyfabricating.com

Tel: 1.905.564.0303
Toll free: 1.866.THE.BULL

Due to continuous product improvements, specifications are subject to change without notice. Some systems and features shown may be optional at extra cost.

CF_HGC_NA_R002